

NOTE:
Please read all instructions
carefully before using this
product

Table of Contents

Safety Notice

Hardware Pack

Assembly Instruction

Parts List

Warranty

Ordering Parts

Model
MD-867W

Retain This
Manual for
Reference

130522

OWNER'S
MANUAL

IMPEX

MARCY DIAMOND ELITE OLYMPIC BENCH

MD-867W

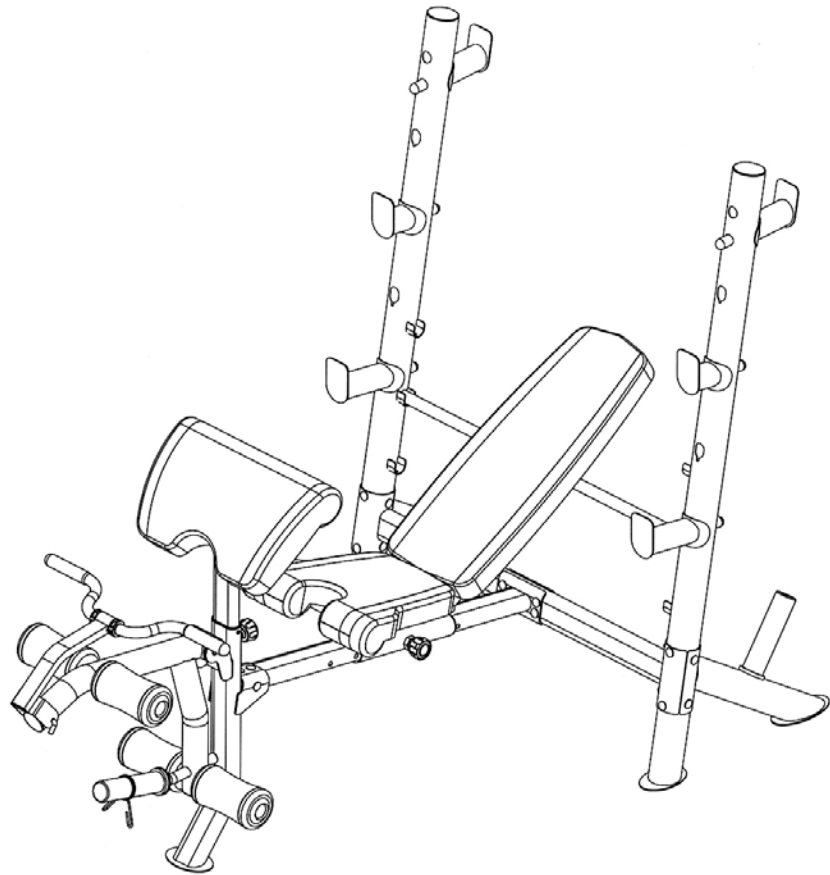

IMPEX[®] INC.

2801 S. TOWNE AVE., POMONA, CA 91766

Tel: (800) 999-8899 Fax: (626) 961-9966

www.impex-fitness.com

info@impex-fitness.com

TABLE OF CONTENTS

BEFORE YOU BEGIN.....	1
IMPORTANT SAFETY NOTICES.....	2
HARDWARE PACK.....	4
ASSEMBLY INSTRUCTIONS.....	6
EXPLODED DIAGRAM.....	11
PARTS LIST.....	12
WARRANTY.....	13
ORDERING PARTS.....	13

BEFORE YOU BEGIN

Thank you for selecting the Marcy Diamond Elite MD-867W BENCH by IMPEX[®] INC. For your safety and benefit, read this manual carefully before using the machine. As a manufacturer, we are committed to provide you complete customer satisfaction. If you have any questions, or find there are missing or damaged parts, we guarantee you complete satisfaction through direct assistance from our factory. To avoid unnecessary delays, *please call our TOLL-FREE customer service number.* Our Customer Service Agents will provide immediate assistance to you.

Toll-Free Customer Service Number

1-800-999-8899

Mon. – Fri. 9 a.m. – 5 p.m. PST

www.impex-fitness.com

info@impex-fitness.com

IMPORTANT SAFETY NOTICE

PRECAUTIONS

This exercise machine is built for optimum safety. However, certain precautions apply whenever you operate a piece of exercise equipment. Be sure to read the entire manual before you assemble or operate your machine. In particular, note the following safety precautions:

1. **Keep children and pets away from the machine at all times. DO NOT leave children unattended in the same room with the machine.**
2. Only one person at a time should use the machine.
3. If the user experiences dizziness, nausea, chest pain, or any other abnormal symptoms, STOP the workout at once. CONSULT A PHYSICIAN IMMEDIATELY.
4. Position the machine on a clear, leveled surface. DO NOT use the machine near water or outdoors.
5. Keep hands away from all moving parts.
6. Always wear appropriate workout clothing when exercising. DO NOT wear robes or other clothing that could become caught in the machine. Running or aerobic shoes are also required when using the machine.
7. Use the machine only for its intended use as described in this manual. DO NOT use attachments not recommended by the manufacturer.
8. Do not place any sharp object around the machine.
9. Disabled person should not use the machine without a qualified person or physician in attendance.
10. Before using the machine to exercise, always do stretching exercises to properly warm up.
11. Never operate the machine if the machine is not functioning properly.
12. A spotter is recommended during exercise.

CARE AND MAINTENANCE

1. Inspect and tighten all parts before using the machine.
2. The machine can be cleaned using a damp cloth and mild non-abrasive detergent. DO NOT use solvents.
3. Maximum on Bar Catch: 300 lbs
4. Maximum weight on Leg Developer: 100 lbs
5. Maximum user weights: 300 lbs
4. Maximum weight capacity 600 lbs (include user's weight).

WARNING: BEFORE BEGINNING ANY EXERCISE PROGRAM, CONSULT YOUR PHYSICIAN. THIS IS ESPECIALLY IMPORTANT FOR INDIVIDUALS OVER THE AGE OF 35 OR PERSONS WITH PRE-EXISTING HEALTH PROBLEMS. READ ALL INSTRUCTIONS BEFORE USING ANY FITNESS EQUIPMENT. IMPEX INC. ASSUMES NO RESPONSIBILITY FOR PERSONAL INJURY OR PROPERTY DAMAGE SUSTAINED BY OR THROUGH THE USE OF THIS PRODUCT.

SAVE THESE INSTRUCTIONS.

WARNING LABEL PLACEMENT

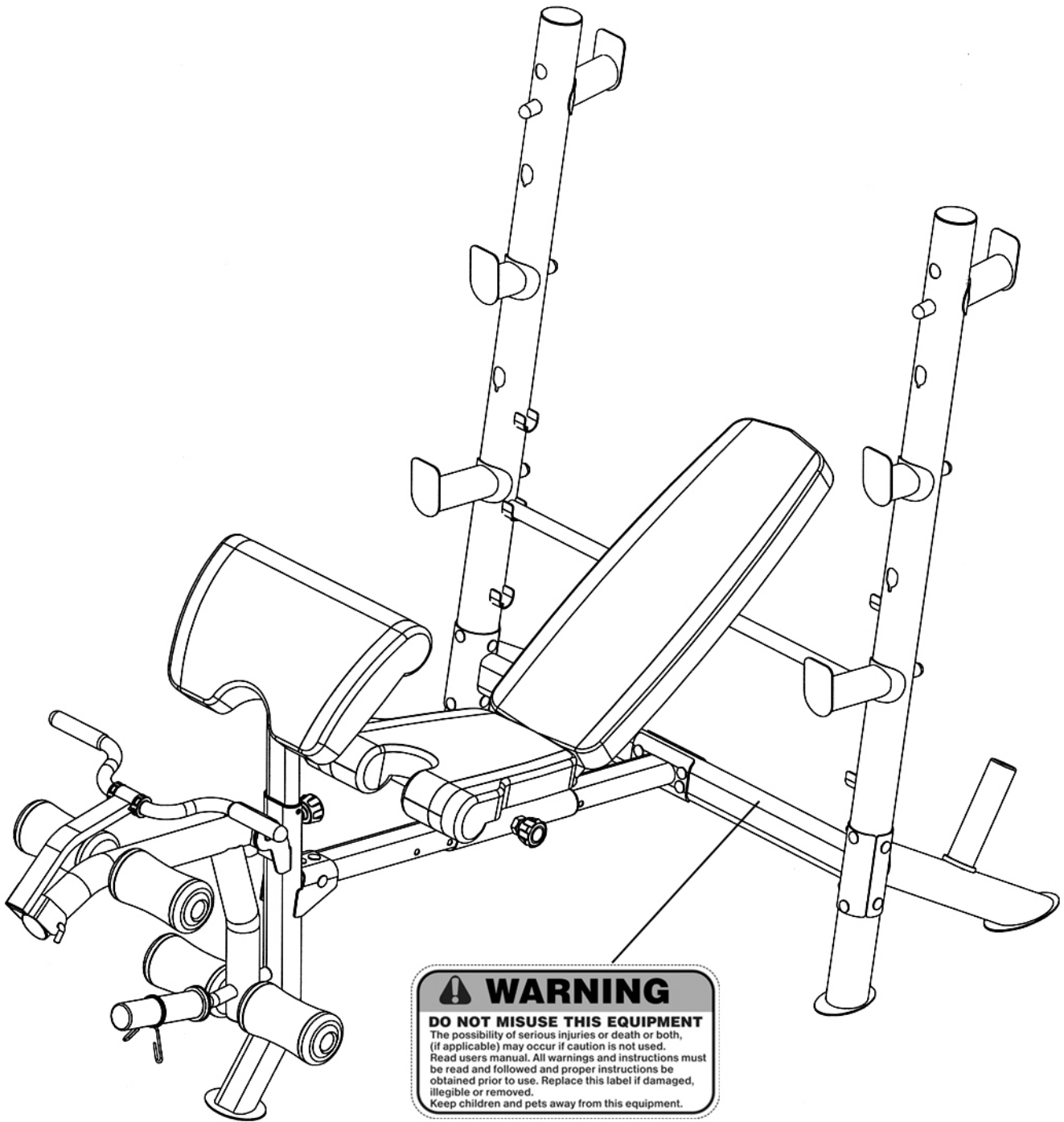

The Warning Label shown here has been placed on the Cross Brace. If the label is missing or illegible, please call customer service at 1-800-999-8899 for replacement. Apply the label in location shown

HARDWARE PACK

NOTE: The following parts are not drawn to scale. Please use your own ruler to measure the size.

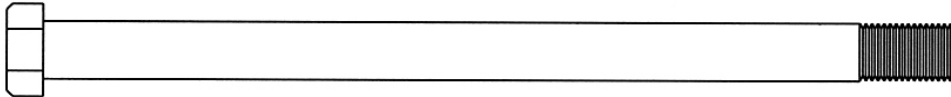

#50 M12 x 7 $\frac{1}{8}$ " Hex Bolt (Qty 1)

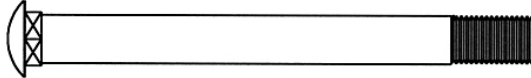

#47 M10 x 4" Carriage Bolt (Qty 1)

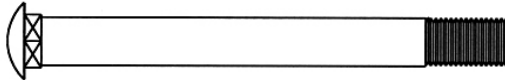

#46 M10 x 3 $\frac{3}{4}$ " Carriage Bolt (Qty 8)

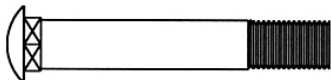

#49 M10 x 2 $\frac{3}{8}$ " Carriage Bolt (Qty 4)

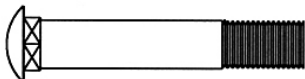

#48 M10 x 2 $\frac{1}{8}$ " Carriage Bolt (Qty 2)

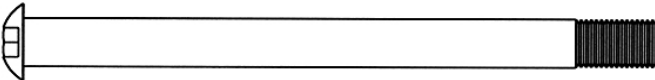

#51 M10 x 5" Allen Bolt (Qty 1)

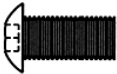

#52 M10 x $\frac{3}{4}$ " Allen Bolt (Qty 2)



#54 M8 x 1 $\frac{5}{8}$ " Allen Bolt (Qty 8)



#53 M8 x $\frac{5}{8}$ " Allen Bolt (Qty 2)

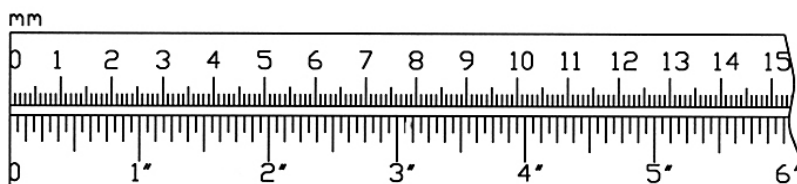

HARDWARE PACK

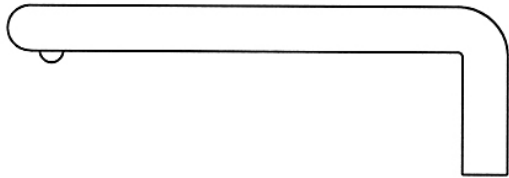

#44 L-shaped Lock Pin (Qty 1)

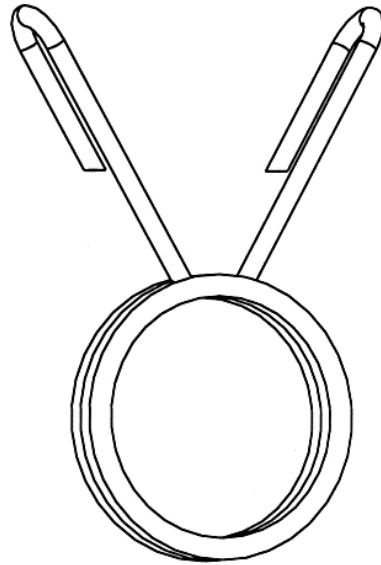

#42 Spring Clip (Qty 1)



#55 $\varnothing \frac{3}{4}$ " Washer (Qty 19)

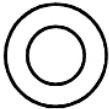

#57 $\varnothing 1$ " Washer (Qty 2)



#56 $\varnothing \frac{5}{8}$ " Washer (Qty 10)



#43 Axle (Qty 1)



#45 $\varnothing \frac{3}{4}$ " x $\frac{1}{4}$ " Bushing (Qty 2)

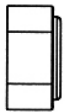

#33 M12 Aircraft Nut (Qty 1)



#58 M10 Aircraft Nut (Qty 16)

ASSEMBLY INSTRUCTION

Tools Required for Assembling the Machine: Two Adjustable Wrenches and Allen Wrenches.

NOTE: It is strongly recommended that two or more people assemble this machine to avoid possible injury.

STEP 1 (See Diagram 1)

- A.) Do not tighten all nuts and bolts until instructed to do so.
- B.) Attach the Left Diagonal Support (#8) to the Left Upright Beam (#1) from rear. Attach the Cross Brace (#5) to the Left Upright Beam from the other side. Secure them together with four M10 x 3 3/4" Carriage Bolts (#46), four Ø 3/4" Washers (#55), and four M10 Aircraft Nuts (#58). Repeat the same step to install the other side of Cross Brace, Right Diagonal Support (#9), and Right Upright Beam (#2) together.
- C.) Place the Backrest Adjustment Bar (#6) onto the selected slot on the Upright Beams to obtain the desired Backrest incline.

DIAGRAM 1

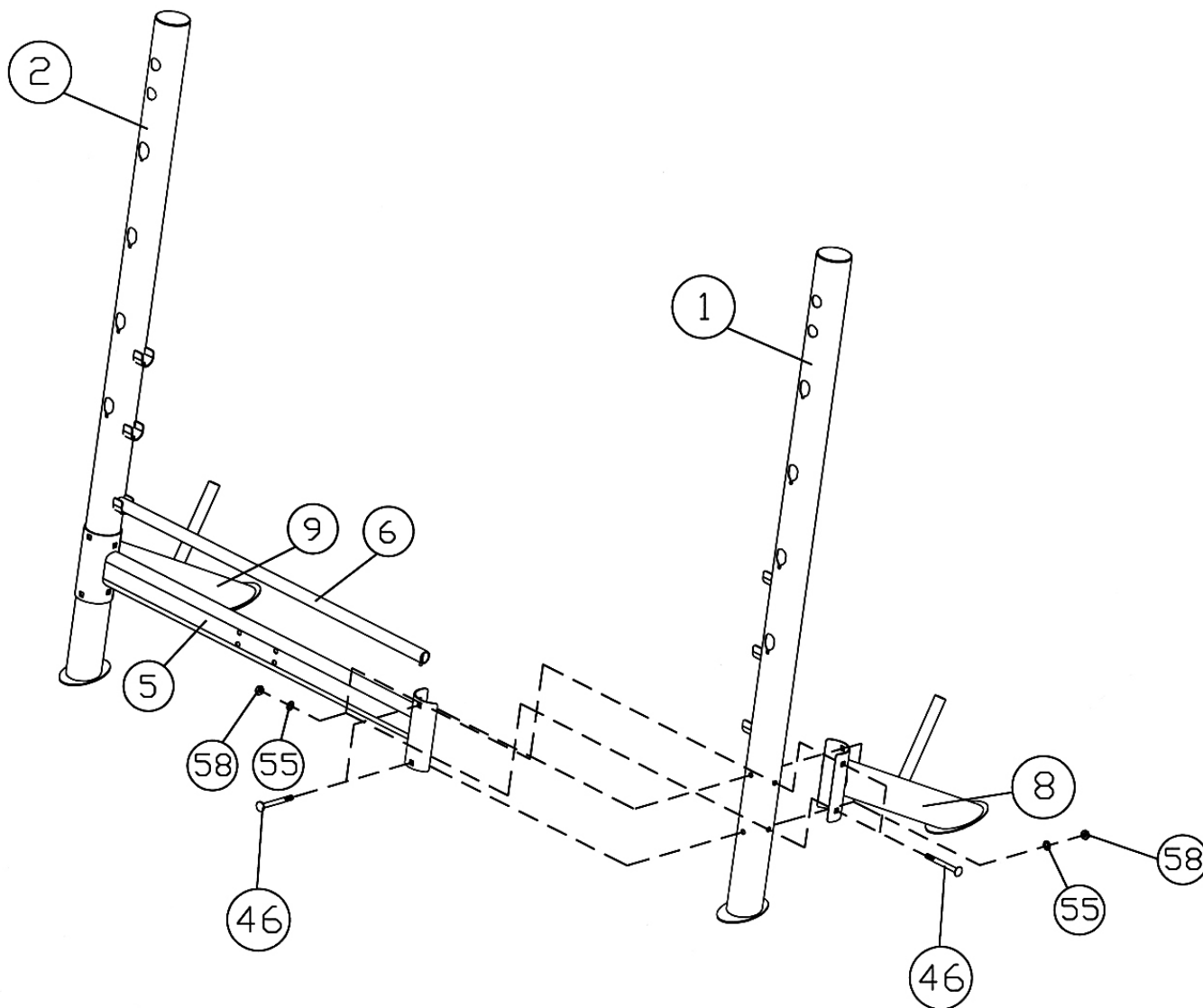

STEP 2 (See Diagram 2)

- A.) **Do not tighten Nuts and Bolts until instructed to do so.**
- B.) Attach the Main Seat Support (#4) to the Cross Brace (#5). Secure it with four M10 x 2 3/8" Carriage Bolts (#49), one 5 1/2" x 3" Bracket (#21), four Ø 3/4" Washers (#55), and four M10 Aircraft Nuts (#58).
- C.) Slide the Sliding Block (#14) onto the Main Seat Support. Use a M18 Lock Knob (#39) to lock the Sliding Block in position.
- D.) Attach the Front Post (#3) to the Main Seat Support. Secure it with one M10 x 4" Carriage Bolt (#47), one Ø 3/4" Washer (#55), and one M10 Aircraft Nut (#58) from side. Secure it with two M10 x 2 1/8" Carriage Bolts (#48), two Ø 3/4" Washers (#55), and two M10 Aircraft Nuts (#58) from top.
- E.) Attach two Squat Bar Catches (#7), two Safety Catches (#15) and two Bar Holders (#16) to Left and Right Upright Beam (#1 & #2).
- F.) Attach two Olympic Sleeves (#26) to the weight post on Left and Right Diagonal Support (#8 & #9).
- G.) **Securely tighten all Nuts and Bolts installed in Step-1 and Step-2.**

DIAGRAM 2

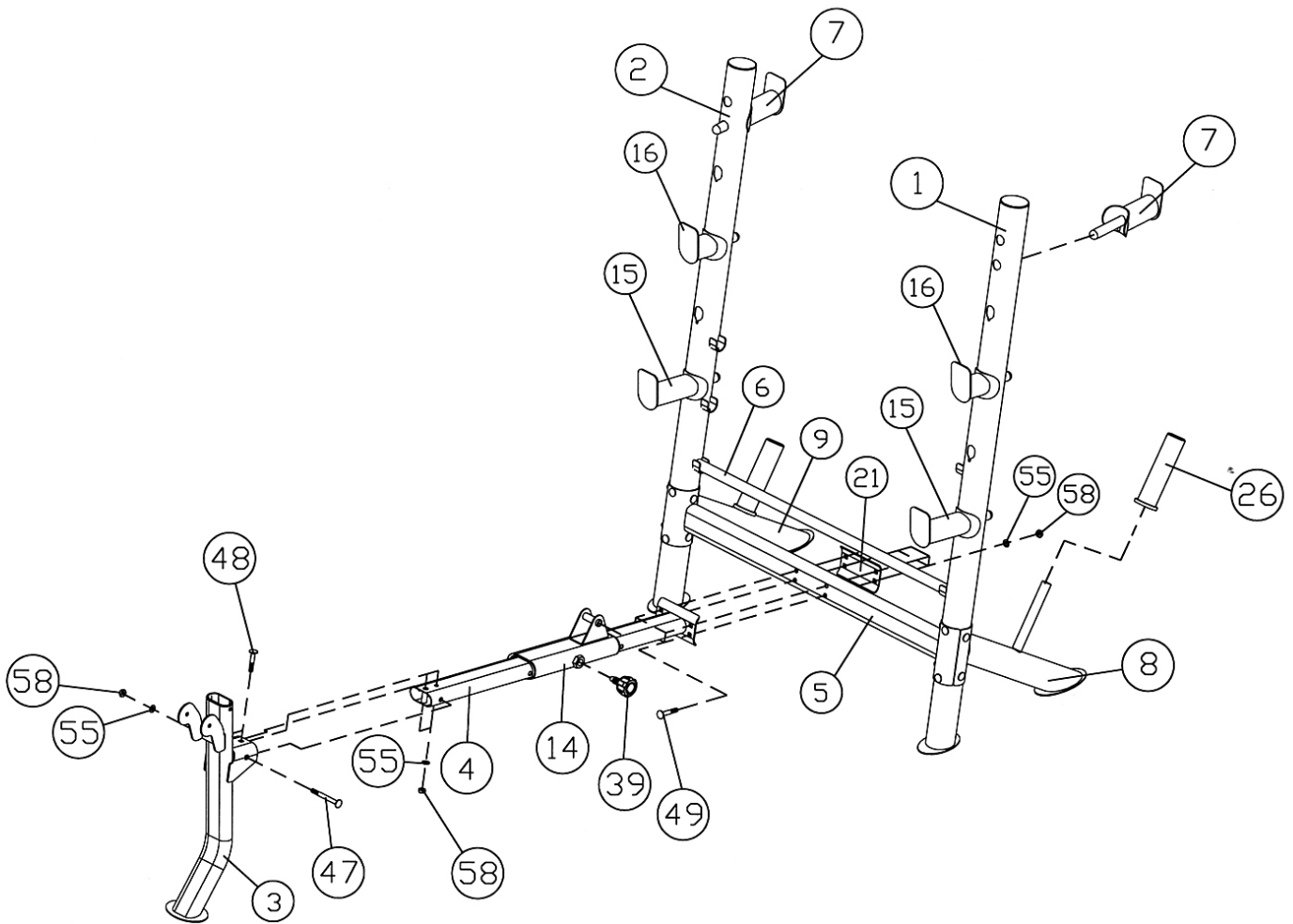

STEP 3 (See Diagram 3)

- A.) Attach the Seat Incline Support (#18) to the opening on Seat Bracket (#17). Secure it with one M10 x 5" Allen Bolt (#51), two Ø 3/4" Washers (#55), and one M10 Aircraft Nut (#58).
Do not tighten the Nut and Bolt yet.
- B.) Attach the Seat Bracket to the pivot on the Sliding Block (#14). Attach the two Backrest Supports (#19) to the Seat Bracket from each side. Secure them together with One M12 x 7 1/8" Hex Bolt (#50), two Ø 1" Washers (#57), and one M12 aircraft Nut (#33).
- C.) Attach the Backrest Board (#22) to the Backrest Supports. Secure it with four M8 x 1 5/8" Allen Bolts (#54) and four Ø 5/8" Washers (#56).
- D.) Attach the Seat Pad (#23) to Seat Bracket. Secure it with four M8 x 1 5/8" Allen Bolts (#54) and four Ø 5/8" Washers (#56).
- E.) **Securely tighten Nut and Bolt installed in A & B.**

DIAGRAM 3

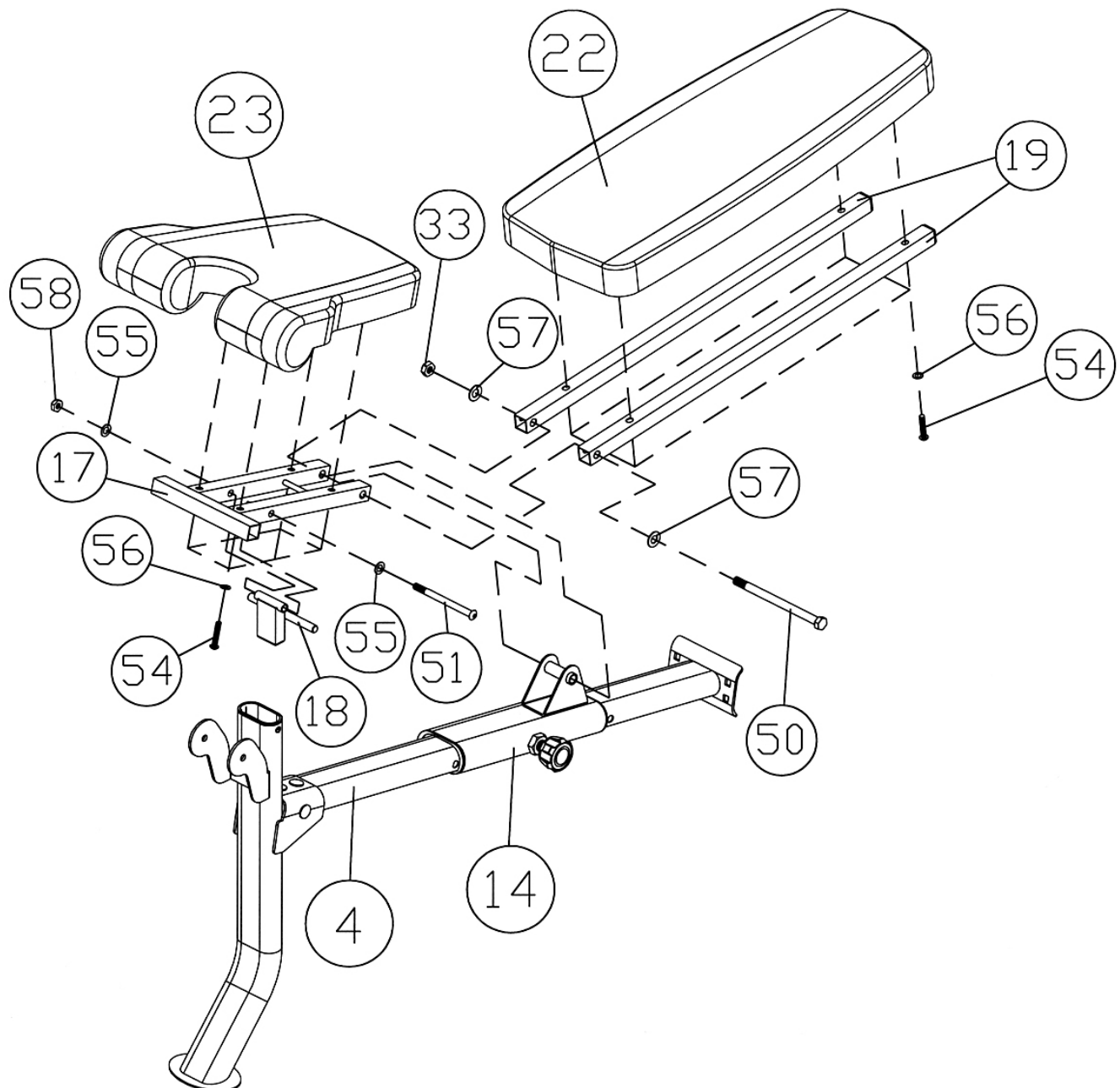

STEP 4 (See Diagram 4)

- A.) Attach the Leg Developer (#11) to the Front Post (#3). Secure it with an Axle (#43), two M10 x 3/4" Allen Bolts (#52) and two \varnothing 3/4" Washers (#55).
- B.) Insert two Foam Tubes (#20) halfway through the holes on the Leg Developer. Push four Foam Rolls (#27) onto the Tubes from both ends. Plug four Foam Roll End Caps (#28) into the ends.
- C.) Slide an Olympic Sleeve (#26) onto the weight post on the Leg Developer. Attach a Spring Clip (#42) to the Sleeve.

DIAGRAM 4

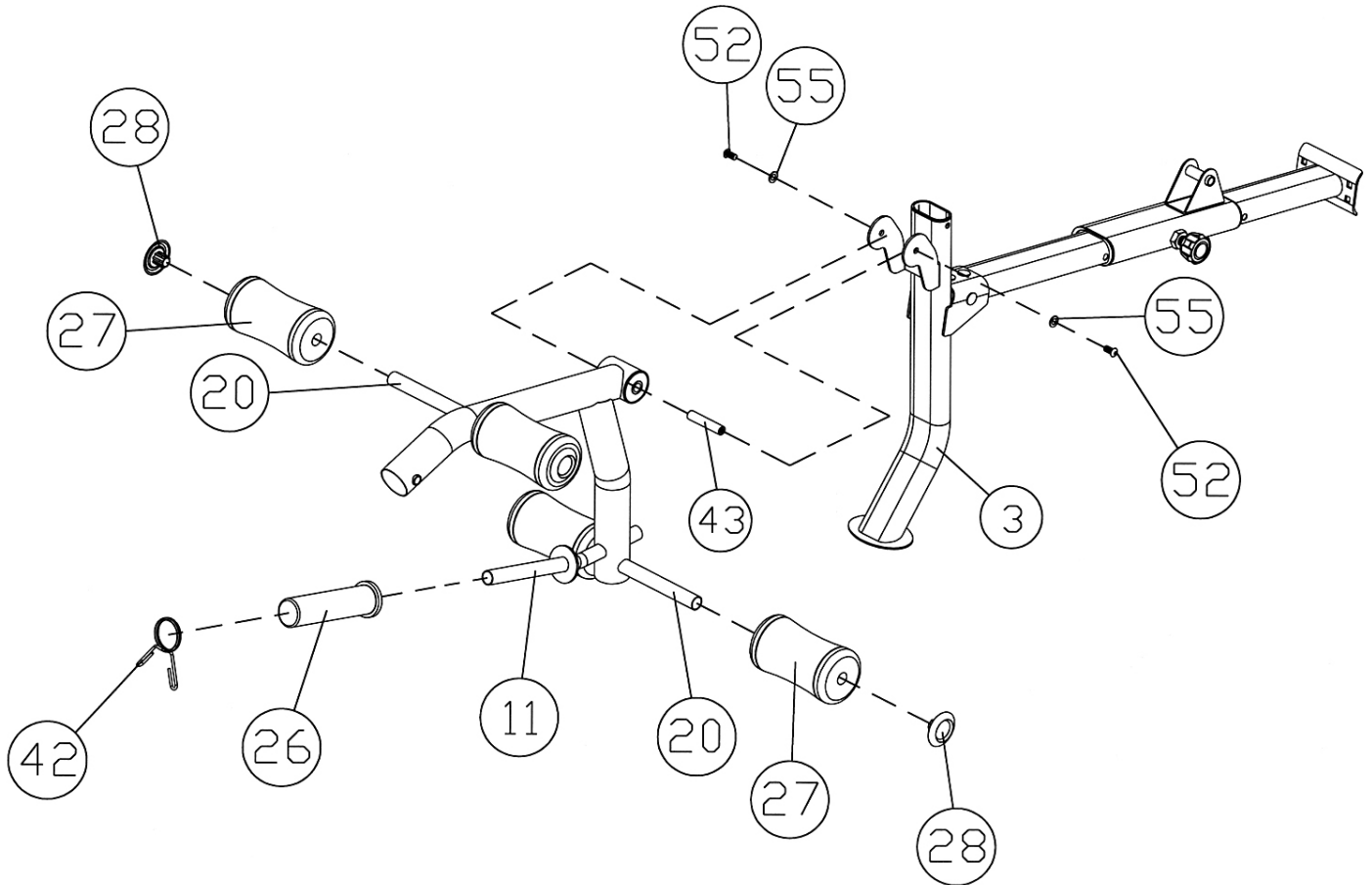

STEP 5 (See Diagram 5)

- A.) Attach the Arm Curl Pad (#24) to the Arm Curl Stand (#10). Secure it with two M8 x 5/8" Allen Bolts (#53) and two Ø 5/8" Washers (#56).
- B.) Insert the Arm Curl Stand into the top opening on the Front Post (#3). Use a M18 Lock Knob (#39) to secure the Arm Curl Stand in position.
- C.) Attach the two Ø 3/4" x 1/4" Bushings (#45) into the holes on Leg Developer. Attach the Curl Bar Handle (#12) to the Leg Developer (#11). Secure it with a L-shaped Lock Pin (#44).
- D.) Remove the Arm Curl Stand and the Curl Bar Handle when using the Leg Developer.

DIAGRAM 5

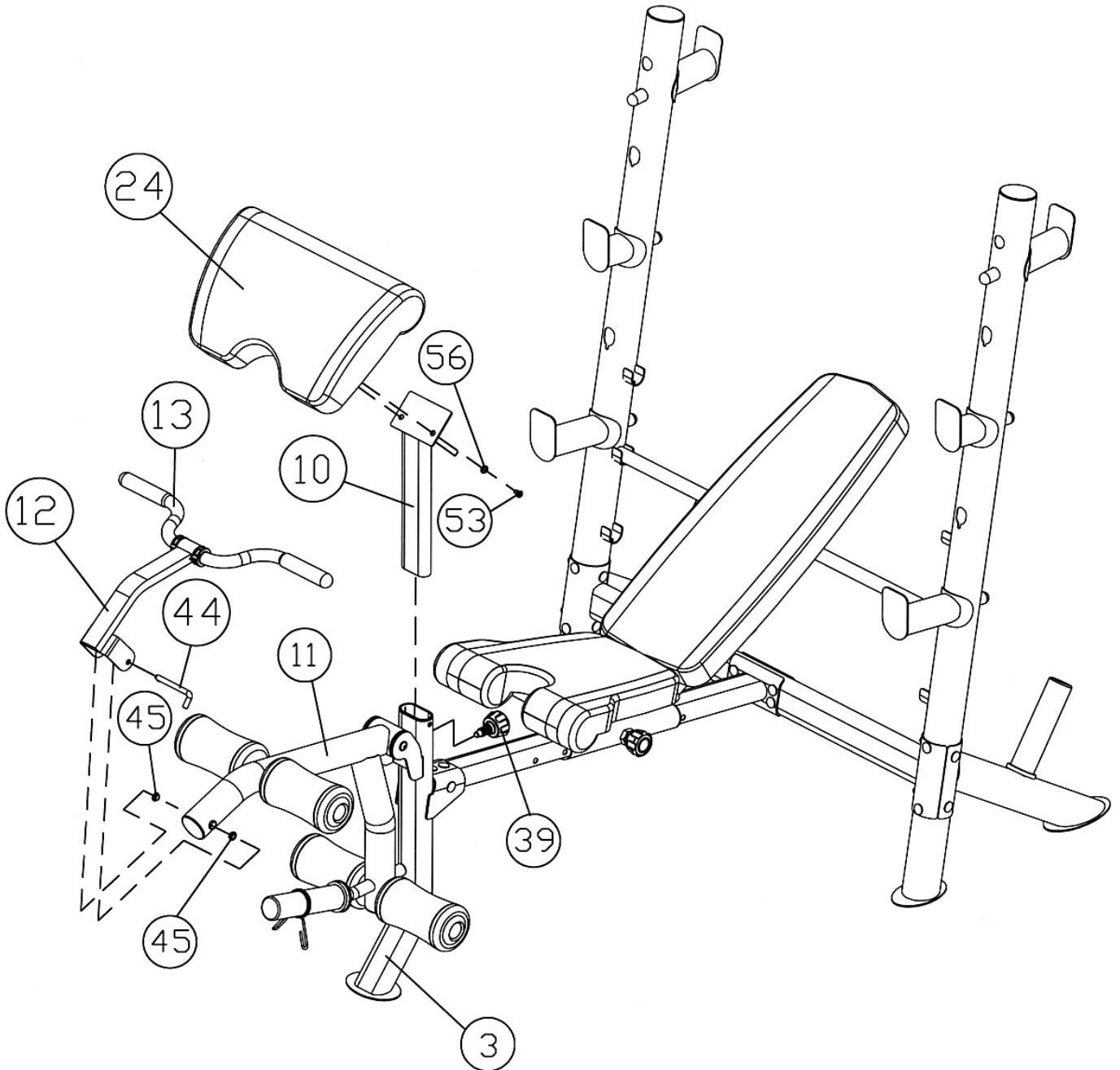

EXPLODED DIAGRAM

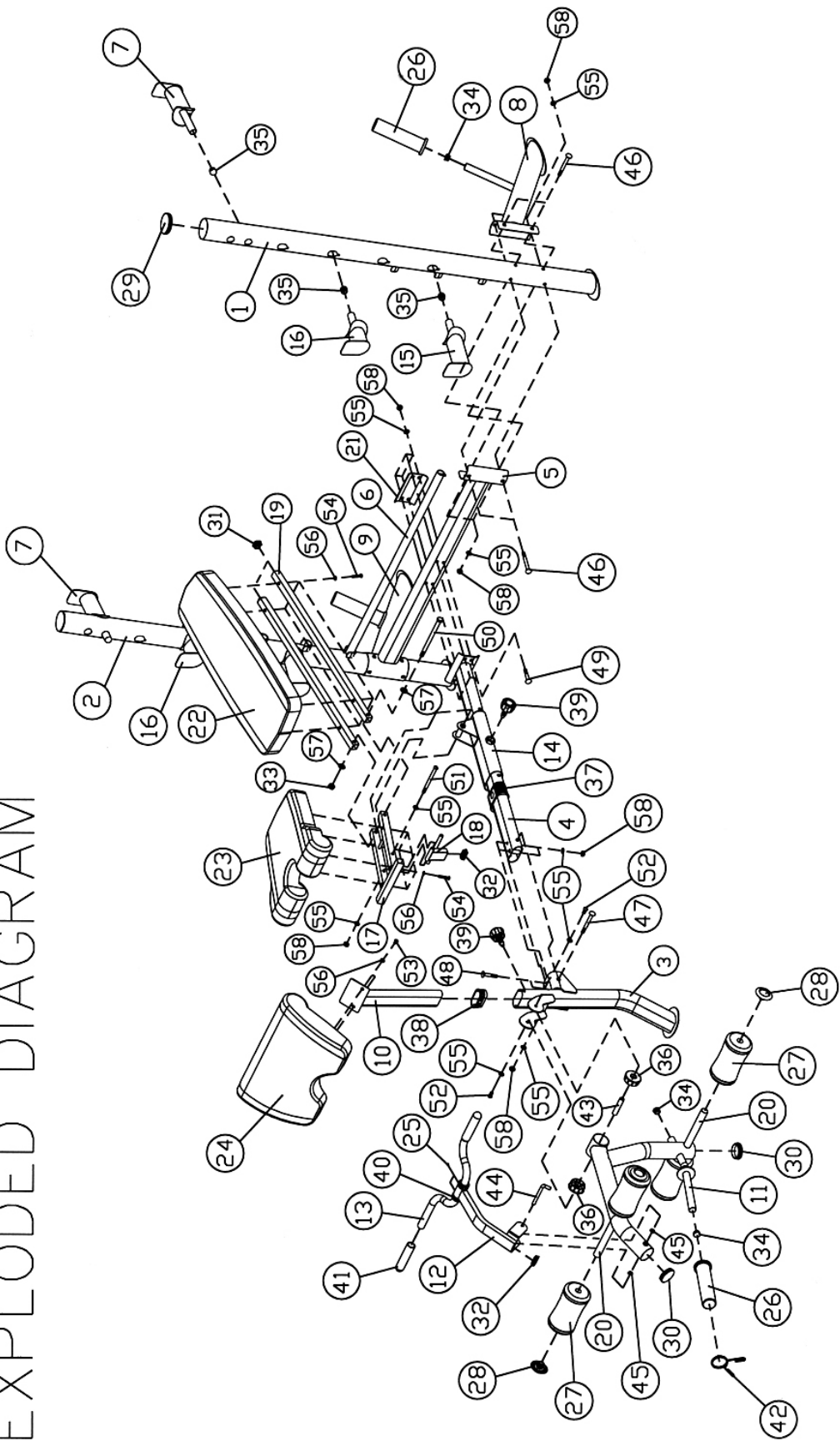

PARTS LIST

KEY NO.	DESCRIPTION	Q'ty			
1	Left Upright Beam	1	51	M10 x 5" Allen Bolt	1
2	Right Upright Beam	1	52	M10 x 3/4" Allen Bolt	2
3	Front Post	1	53	M8 x 5/8" Allen Bolt	2
4	Main Seat Support	1	54	M8 x 1 5/8" Allen Bolt	8
5	Cross Brace	1	55	Ø 3/4" Washer	19
6	Backrest Adjustment Bar	1	56	Ø 5/8" Washer	10
7	Squat Bar Catch	2	57	Ø 1" Washer	2
8	Left Diagonal Support	1	58	M10 Aircraft Nut	16
9	Right Diagonal Support	1		4# Allen Wrench (Tool)	1
10	Arm Curl Stand	1		5# Allen Wrench (Tool)	1
11	Leg Developer	1		6# Allen Wrench (Tool)	2
12	Curl Bar Handle	1			
13	Curl Bar	1			
14	Sliding Block	1			
15	Safety Bar Catch	2			
16	Bar Holder	2			
17	Seat Bracket	1			
18	Seat Incline Support	1			
19	Backrest Support	2			
20	Foam Tube	2			
21	5 1/2" x 3" Bracket	1			
22	Backrest Board	1			
23	Seat Pad	1			
24	Arm Curl Pad	1			
25	Rivet	2			
26	Olympic Sleeve	3			
27	Foam Roll	4			
28	Foam Roll End Cap	4			
29	Ø 3" End Cap	2			
30	Ø 2 3/8" End Cap	2			
31	1" Square End Cap	2			
32	3/4" x 1 5/8" End Cap	2			
33	M12 Aircraft Nut	1			
34	Ø 1" End Cap	4			
35	Ø 1" Cone-shaped End Cap	6			
36	Ø 2 3/8" x 7/8" Bushing	2			
37	4" Sleeve	2			
38	3 1/8" Sleeve	1			
39	M18 Lock Knob	2			
40	Plastic Ring	2			
41	Grip	2			
42	Spring Clip	1			
43	Axle	1			
44	L-shaped Lock Pin	1			
45	Ø 3/4" x 1/4" Bushing	2			
46	M10 x 3 3/4" Carriage Bolt	8			
47	M10 x 4" Carriage Bolt	1			
48	M10 x 2 1/8" Carriage Bolt	2			
49	M10 x 2 3/8" Carriage Bolt	4			
50	M12 x 7 1/8" Hex Bolt	1			

IMPEX[®] INC.

LIMITED WARRANTY

IMPEX Inc. ("IMPEX[®]") warrants this product to be free from defects in workmanship and material, under normal use and service conditions, for a period of two years on the Frame from the date of purchase. This warranty extends only to the original purchaser. IMPEX's obligation under this Warranty is limited to replacing or repairing, at IMPEX's option.

All returns must be pre-authorized by IMPEX. Pre-authorization may be obtained by calling IMPEX Customer Service Department at 1-800-999-8899. All freights on products returned to IMPEX must be prepaid by the customer. This warranty does not extend to any product or damage to a product caused by or attributable to freight damage, abuse, misuse, improper or abnormal usage. No other warranty beyond that specifically set forth above is authorized by IMPEX.

IMPEX is not responsible or liable for indirect, special or consequential damages arising out of or in connection with the use or performance of the product or other damages with respect to any economic loss, loss of property, loss of revenues or profits, loss of enjoyments or use, costs of removal, installation or other consequential damages or whatsoever natures. Some states do not allow the exclusion or limitation of incidental or consequential damages. Accordingly, the above limitation may not apply to you.

The warranty extended hereunder is in lieu of any and all other warranties and any implied warranties of merchantability or fitness for a particular purpose is limited in its scope and duration to the terms set forth herein. Some states do not allow limitations on how long an implied warranty lasts. Accordingly, the above limitation may not apply to you.

This warranty gives you specific legal right. You may also have other rights which vary from state to state. **Register on-line at www.impex-fitness.com**

IMPEX[®] INC.
2801 S. Towne Ave.
Pomona, CA 91766

ORDERING REPLACEMENT PARTS

Replacement parts can be ordered by calling our Customer Service Department toll-free at **1-800-999-8899** during our regular business hours: Monday through Friday, 9 am until 5 pm Pacific standard time.
info@impex-fitness.com

When ordering replacement parts, always give the following information.

1. Model
2. Description of Parts
3. Part Number
4. Date of Purchase